

10-120 kVA

UPS USER MANUAL

STARTING PROCESS

1. Complete the internal battery connections.
2. Connect the device mains and load connections.
3. Turn F1 (input) breaker ON.
4. Wait for 5 seconds for the front panel to open.
5. From the front panel, check that the device is in "bypass mode"
6. The device will give warning because it is in "bypass mode"
7. Turn F2 (output) breaker ON.
8. Press the ON button once and the alarm will stop.
9. Press the ON button for a second time and see "LINE START" warning
10. After ten seconds the device will display "ONLINE MODE".
11. Check that the battery charging voltages of the device are generated.
12. Set F3 (battery) breaker to ON position.
13. Turn F1 (input) breaker OFF to see that the device is operating on battery.
14. Check that the device is in ONLINE MODE by turning F1 (input) breaker ON.





CLOSING PROCESS

1. Switch off the load safely before starting the closing process of the device!
2. Make sure the loads are switched off!
3. Set F2 (output) breaker to OFF.
4. Turn F3 (battery) breaker OFF.
5. Press and hold the ON button for 5 seconds.
6. Check that the device is in "BYPASS MODE"
7. Press the ON and SELECT buttons at the same time to see that the LCD panel of the device is turned off.
8. Set F1 (input) breaker to OFF.

Important Notices!

Dear User;

This manual contains important information about technical properties, installation, commissioning of the UPS and contains safety information for users and loads. Learning and applying of the subjects in this manual is necessary to use UPS safely and correctly.

	Read the manual completely before working on this equipment!
	Keep this manual near UPS for easy consultation!
	Reproduction, adaptation, or translation of this manual is prohibited without prior written permission of Manufacturer Company, except as allowed under the copyright laws.
	<i>The manufacturer reserves the rights to change the technical specifications and design without notice.</i>

Life span of the device is 10 years.

This UPS is designed to meet the requirements specified in EN 62040-1 and EN 62040-2 Standards

This UPS complies with the norms of the following marking.



Abbreviations and Descriptions

- **UPS:** Uninterruptible Power Systems
- **Batt:** Battery
- **EPO:** Emergency Power Off
- **RS232:** Serial Communication Protocol
- **SNMP:** Simple Network Management Protocol
- **V:** Volt (Voltage)
- **A:** Amper (Current)
- **P:** Power(Watt)
 - For Input ,Output,Battery and Manual Bypass Circuit Breaker;
 - "I" (ON): Closing the Circuit
 - "O" (OFF): Opening the Circuit

Symbols Used in the Manual



This symbol points out the instructions which are especially important.



This symbol points out the risk of electric shock if the following instruction is not obeyed.



This symbol points out the instructions, which may be resulted with the injury of the operator or damage of the equipment if not obeyed



This symbol indicates that the transport materials used for UPS are recyclable.



Explanation of Symbols

	<p><i>PE: PROTECTIVE EARTH</i></p>
	<p><i>Electroshock Hazard (Black/Yellow)</i></p>
	<p><i>This symbol points out the instructions, which may be resulted with the injury of the operator or damage of the equipment if not obeyed</i></p>
	<p><i>Recycle</i></p>
	<p><i>Heavy load</i></p>

CONTENTS

1. SAFETY INSTRUCTIONS	6
2. GENERAL INSTRUCTIONS	7
2.1. Safety Transportation	7
2.2. Placement	8
2.3. Storage	9
3. UNPACKING AND INSTALLATION	10
3.1. Unpacking	10
3.2. Installation Procedures	11
3.3. (3F Input/ 3F Output) UPS Dimensions and General View	12
3.3.1 10kVA-15kVA-20kVA PF:0,8-0,9 / 10kVA-15kVA PF:1 UPS Dimensions	12
3.3.2 30kVA-40kVA PF:0,8-0,9 / 20kVA-30kVA PF:1 UPS Dimensions	12
3.3.3 40kVA PF:1 / 60kVA PF:0,8-0,9 UPS Dimensions	13
3.3.4 10kVA-60kVA UPS Rear Panel View	13
3.3.4.1 10kVA-60kVA UPS Power Connection Terminals	14
3.3.4.2 10kVA-60kVA UPS Power Connection Terminals	14
3.3.4.3 10kVA-60kVA UPS Fuse and Switchgear Description	15
3.3.4.4 10kVA-60kVA UPS Optional and Standard Accessories Description	15
3.4. 60kVA PF:1 / 80kVA PF:0,8-0,9 / 120kVA PF:0,8-0,9 UPS Dimensions	16
3.4.1. 80kVA-120kVA (3F Input/ 3P Output) UPS Power Connection Terminals and Switchgear Placement	17
3.4.2. 80kVA-120kVA (3F Input/ 3P Output) UPS Power Connection Terminals	17
3.4.3. 80kVA-120kVA (3F Input/ 3P Output) UPS Fuse and Switchgear Description	18
3.4.4 10kVA-120kVA UPS General View	18
3.5. UPS Connection Descriptions	19
3.6. Protective Earth (PE) Connection	19
3.7. Input Connection	19
3.8. Battery Connection	20
3.9. Output Connection	21
3.10. Dry Contact Connection	21
3.11. Serial Communication (RS232)/External SNMP Adapter	22
3.12. Emergency Power Off and External Battery Cabinet Temperature Measurement(Optional)	23
4. OPERATION MODES	24
4.1. Bypass Mode	25
4.2. Online Mode	26
4.3. Battery Mode	26
4.3.1. Battery Management and Battery Back-Up Time	27
4.4. Maintenance Failure Mode	27
4.5. Closed Mode	27
5. FRONT PANEL	28
5.1. Display(LCD)	28
5.2. Menu	29
5.3. Menus and Description	30
6. START UP	31
6.1. UPS Start Up	31
6.2. UPS Shutdown	31
6.3. Emergency Power Off(EPO)	32
7. MAINTENANCE	33
7.1. Batteries	33
7.2. Fans	33
8. TROUBLESHOOTING	34
8.1. Output Short Circuit Alarm	34
8.2. Battery Failure Alarm	34
8.3. Faults Warnings	35
9. TECHNICAL SPECIFICATIONS	36
10. WARRANTY	37
10.1. Warranty Conditions	37
10.2. UPS's Out of Warranty Situations	37

1 SAFETY INSTRUCTIONS

<p>Life Safety</p> 	<p>Use the UPS where there is restricted Access (TS EN 62040-1-2).</p> <p>The UPS has its own energy source (Batteries). So, even if all the switches are thrown off, there will be energy at the output.</p> <p>There is high voltage inside of the UPS. So, the UPS must be open only by qualified service personnel.</p> <p>The UPS must be grounded according to the rules.</p> <p>Explosion Hazard: Do not litter batteries in fire.</p> <p>Do not open the plastic cover of the batteries. Electrolyte liquid inside batteries is highly hazardous to skin and eyes.</p> <p>Comply with all applicable regulations for disposal of waste batteries.</p>
<p>Ups Safety</p> 	<p>The UPS must be protected by a circuit breaker easily accessible in short circuit and overload case.</p> <p>If the environment temperature and relative humidity are out of value specified in the manual, do not operate the UPS.</p> <p>Do not operate the UPS in a liquid or excessive moisture environment.</p> <p>Do not allow a liquid or a foreign object to enter into the UPS.</p> <p>Do not block the ventilation grids located on the UPS.</p> <p>Do not leave the UPS exposed to direct sunlight or heat source.</p> <p>Lifetime of the UPS is 10 years.</p>
<p>Replacing the Batteries and Recycling</p> 	<p>Replacing the batteries must be done by authorized service staff.</p> <p>Metal accessories such as watch, ring, etc. must be taken to prevent personal accidents. Gumshoe and glove must be used.</p> <p>Tools with dielectric handle must be used.</p> <p>Be sure that battery connections are not grounded by mistake.</p> <p>Do not put tool or metal accessory above batteries.</p> <p>Battery has an electric shock and short circuit shock.</p> <p>Batteries must be replaced with batteries of the same capacity and same type, same quantity and same sizes.</p> <p>Recycling of batteries must be provided. Deliver batteries to any recycling plant with packaging material of batteries.</p>

2 GENERAL INSTRUCTIONS

2.1 Safety Transportation



- Be careful when moving the load. Do not carry heavy loads without assistance.
- Wheeled UPS must be move unhindered and smooth surfaces
- Do not use a ramp inclined more than 10° angle.
- Follow the following recommendations for load weights.
 - o An adult human can carry loads up to 18 kg.
 - o Two adult human can carry loads up to 32 kg.
 - o Three adult human can carry loads up to 55 kg.
 - o Use pallet truck and forklift to move loads are heavy than 55 kg.
- The UPS should be packed properly when it needs to be carried again. For this reason, it is recommended to save the original package.

Environment Requirement

Working temperature	0/40 °C (15-25 °C for maximum battery life)
Maximum relative humidity	95% max. without condensation
Maximum altitude without derating	2.000 m
Degree of protection	IP 20 (other IP as option)

2.2. Placement

This product meets the safety requirements for devices to be operated in restricted access locations according to EN 62040-1 and EN 60950-1 safety standard, which states that the owner should guarantee the following:

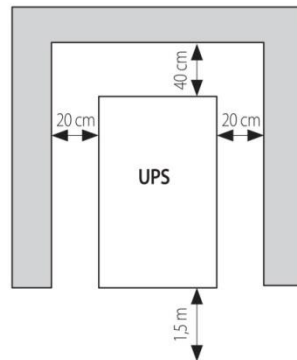

Unsuitable conditions for Ups



Harmful fumes, abrasive dust
Humidity, vapor, bad air, raw
Explosive dust and gas mixture
Over temperature variation
Bad ventilation
Be exposure to heat in direct or with radiation from other sources
Intense electromagnetic field
Harmful level of radioactive
Insect, rabble, fungus, etc
The UPS is not design to run in outdoor open area.
No receipt of direct sunlight, far from the heating, in a dry place.
Please store the UPS in an environment where the temperature is between 0 °C ile +40 °C ,It is suggested to provide an environment temperature between 20-25°C to get maximum performance from the UPS and batteries. Adviced Environmental humidity condition is between 20% 80% (non-condensing)
Make sure that the floor can support the weight of the system.

2.3. Storage

- Please store the UPS in an environment where the temperature is between -25°C and +55°C, no receipt of direct sunlight, far from the heating, in a dry place. For internal battery upss please store the ups where the temperature is between -15°C and +25°C otherwise batteries may damage
- Environmental humidity must be between 20% 80% (none condensing).
- If the batteries will be stored for longer than 3 months, they shall be charged periodically
- Charge period depends on the storage temperature. The relationship is as shown below:
 - Every 9 months if the temperature is below 20°C,
 - Every 6 months if the temperature is between 20°C and 30°C,
 - Every 3 months if the temperature is between 30°C and 40°C,
 - Every 2 months if the temperature is over 40°C

- Check the conformity of the total load and mains with the UPS.
- The UPS must be stored in place is terms of moisture dry conditions between -10°C and 45°C before installation.
- The UPS must be operated at least once a month to charge batteries during 24 hours.
- Storage time is limited due to battery life starts in production date.

3. UNPACKING AND INSTALLATION OF THE UPS



Equipment and batteries whose packages are damaged during transportation shall be inspected by qualified Technical Personnel before starting with the installation.



If any equipment has been damaged during shipment, keep the shipping and packing materials for the carrier or place of purchase and file a claim for shipping damage. If you discover damage after acceptance, file a claim for concealed damage.



UPS output voltage and frequency is set to 220V/50Hz, as default.



It is recommended to store the original UPS packaging for future needs.

3.1. Unpacking of the Ups

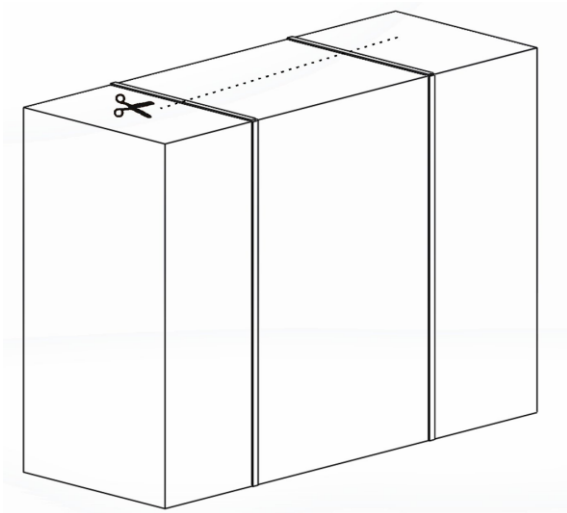

Cut the black protection band shown in figure

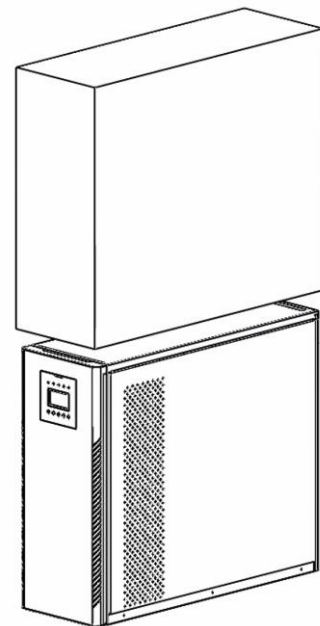

Remove the nylon protective material inside the card box. Lift the carton upwards to remove

3.2. Installation Procedures

The UPS must be installed according to standards below:

- TS HD 384.4.482.S1: Electric Wiring in Buildings chapter 4: Safety Protection-Group 48: Choosing of Protective Measures Which is Depend on External Effects-Section 482: Protection against Fire at the Places Where There Are Special Risk or Danger.

The electrical distribution panels for the mains and separated bypass mains inputs must have a protection and disconnection system. Disconnection devices used in these panels shall disconnect all line conductors simultaneously. During transitory phases (power failure, return and voltage fluctuations) short leakage current peaks may occur. Make sure that the protection is not activated in such cases.



Connections must only be made by Authorized Technical Personnel. The user's attempt to make connections on his own can be life-threatening.



When the UPS is brought from a cold place to a warmer place, humidity of the air may condensate in it. In this case, wait for 2 (two) hours before beginning with the installation.



Devices with internal batteries may have dangerous voltages on the battery terminals.

3.3. (3F Input/ 3F Output) UPS Dimensions and UPS General View

3.3.1 10kVA-15kVA-20kVA PF:0,8-0,9 10kVA-15kVA PF:1 UPS Dimensions

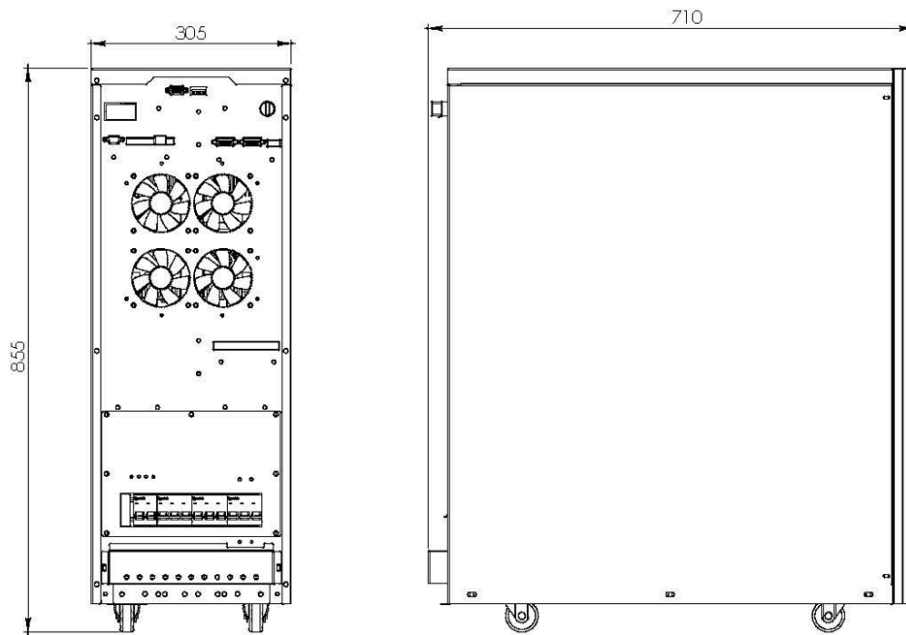

3.3.2 30kVA-40kVA PF:0,8-0,9 20kVA-30kVA PF:1 UPS Dimensions

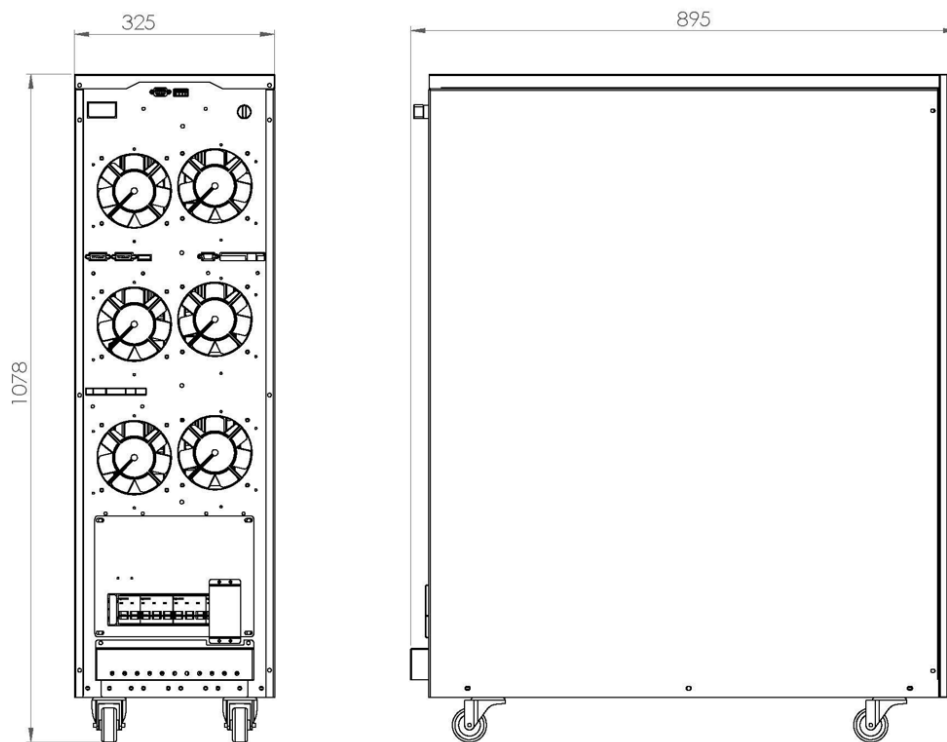

3.3.3 40kVA PF:1 60kVA PF:0,8-0,9 UPS Dimensions

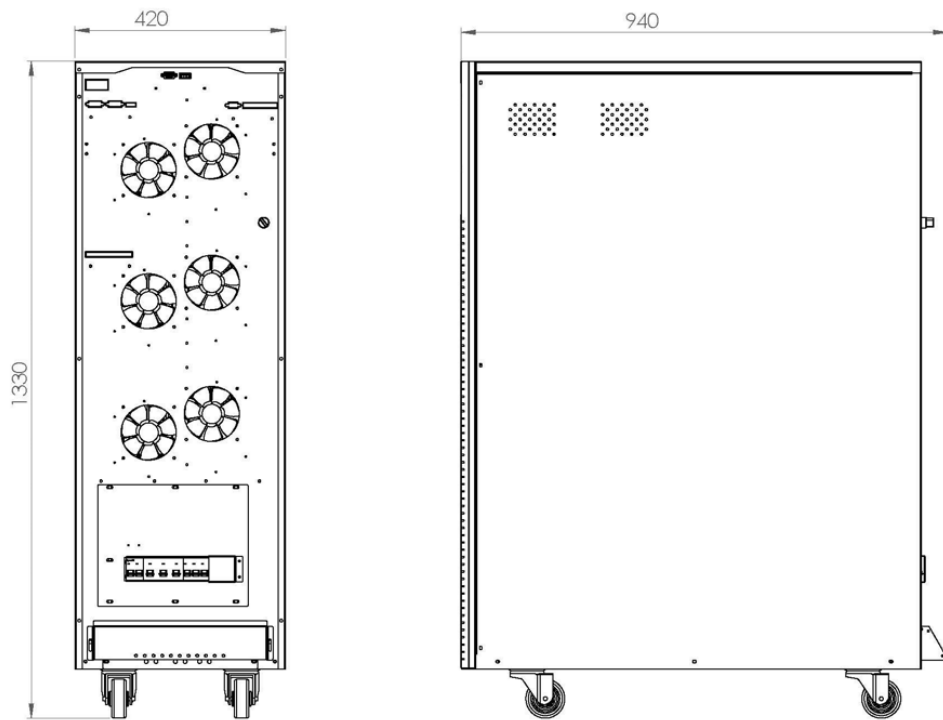

3.3.4 10kVA-60kVA UPS Rear Panel Details

10kVA-15kVA-20kVA PF:0,8-0,9
10kVA-15kVA PF:1

30kVA-40kVA PF:0,8-0,9
20kVA-30kVA PF:1

40kVA PF:1
60kVA PF:0,8-0,9

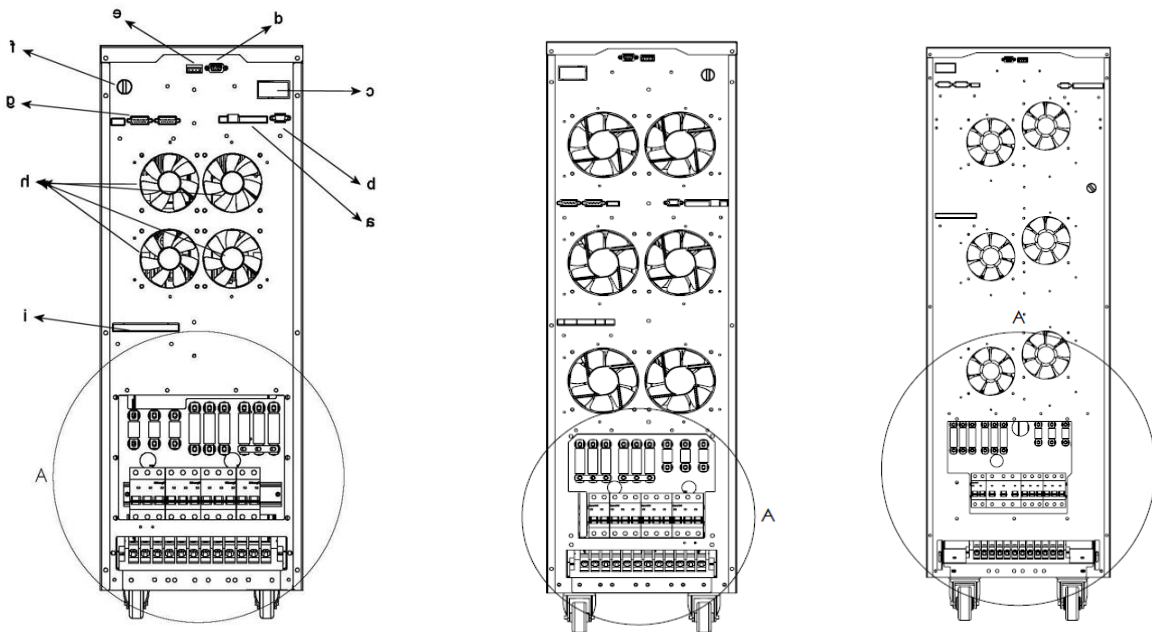

3.3.4.1 10kVA-60kVA UPS Power Connections Terminals Details

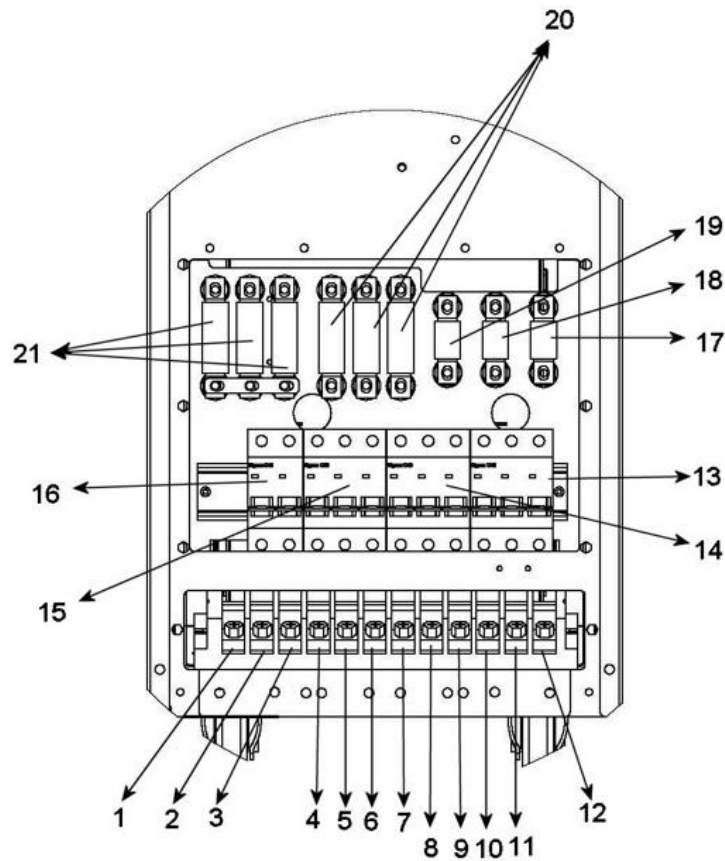

3.3.4.2 10kVA-60kVA UPS Terminal Connection Descriptions

Battery	1	BATT + (Plus) connection terminal
	2	BATT N middle point connection terminal
	3	BATT – (Minus) connection terminal
OUTPUT	4	OUTPUT PHASE R connection terminal
	5	OUTPUT PHASE S connection terminal
	6	OUTPUT PHASE T connection terminal
	7	OUTPUT NEUTRAL connection terminal
INPUT	8	MAINS PHASE R connection terminal
	9	MAINS PHASE S connection terminal
	10	MAINS PHASE T connection terminal
	11	MAINS NEUTRAL connection terminal
PROTECTIVE EARTH	12	Protective Earth connection terminal

3.3.4.3 10kVA-60kVA UPS Fuse and Switchgear Descriptions

F1	13	Manual By-Pass
F2	14	Input Switch
F3	15	Output Switch
F4	16	Battery Switch
Fuse	17	T Phase Input Fuse
Fuse	18	S Phase Input Fuse
Fuse	19	R Phase Input Fuse
Fuse	20	Battery Negative (-) Fuse
Fuse	21	Battery Positive (+) Fuse

3.3.4.4 10kVA-60kVA UPS Optional and Standard Accessories Descriptions

a	Dry Contact Terminals
b	Communication Terminal
c	SNMP
d	RS232
e	EPO/Battery Temperature Sensor
f	Service Switch
g	Paralel Input and Outputs
h	12Vdc Fans
i	Paralel Operation Card

3.4 60kVA PF:1 80kVA PF:0,8-0,9 120kVA PF:0,8-0,9 UPS Dimensions

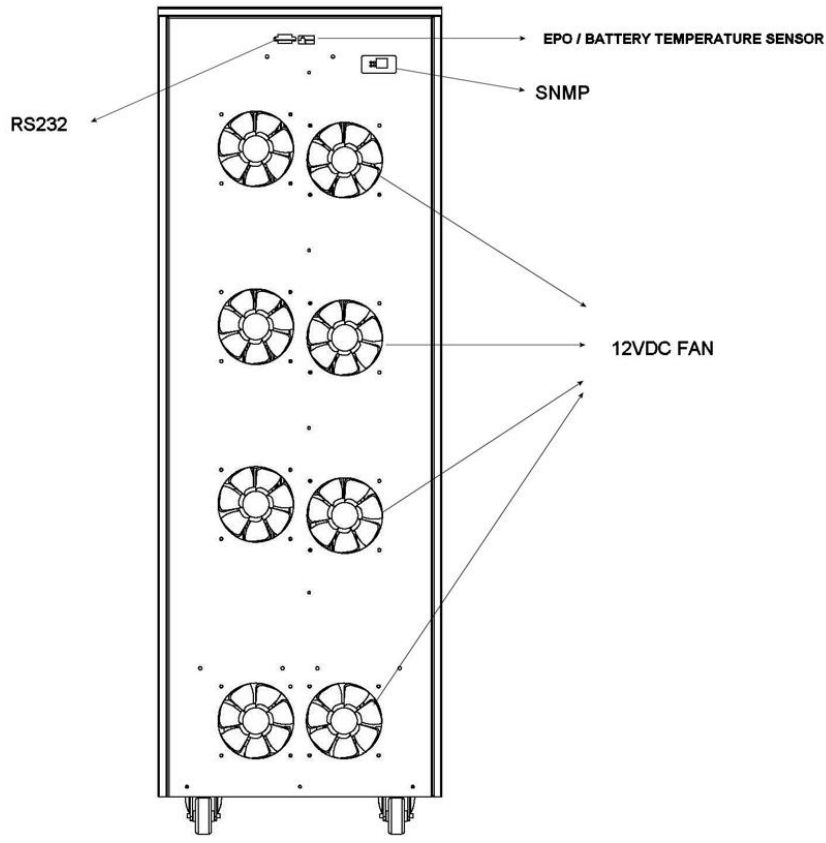
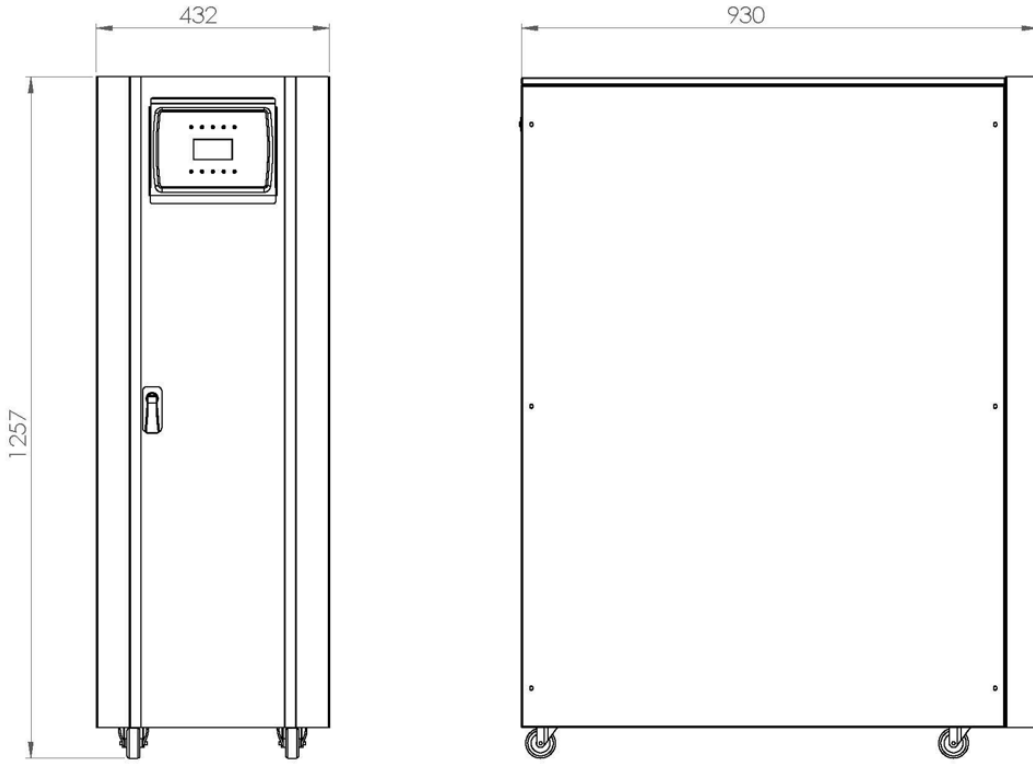

3.4.180kVA-120kVA (3F Input/ 3P Output) UPS Terminal Connections and Switchgear Placement

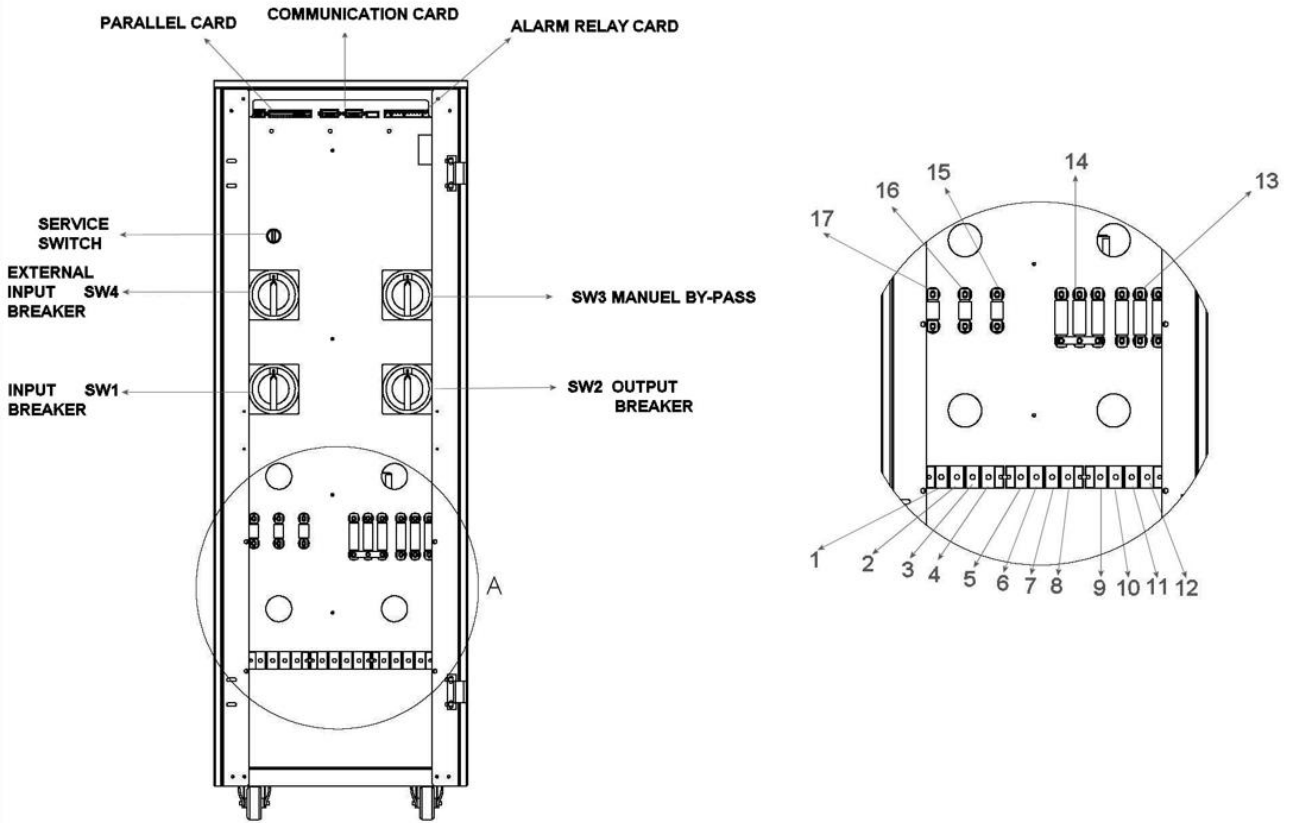

3.4.2 80kVA-120kVA (3F input/ 3P Output) UPS Terminal Connection

INPUT	1	MAINS PHASE R connection terminal
	2	MAINS PHASE S connection terminal
	3	MAINS PHASE T connection terminal
	4	MAINS NEUTRAL connection terminal
OUTPUT	5	OUTPUT PHASE R connection terminal
	6	OUTPUT PHASE S connection terminal
	7	OUTPUT PHASE T connection terminal
	8	OUTPUT NEUTRAL connection terminal
BATTERY	9	BATT + (plus) connection terminal
	10	BATT N middle point connection terminal
	11	BATT – (Minus) connection terminal
PROTECTIVE EARTH	12	Protective Earth connection terminal

3.4.3 80kVA-120kVA (3F Input/ 3P Output) UPS Switchgear and Fuse Descriptions

SW1		Input Switch
SW2		Output Switch
SW3		Manual By-Pass
SW4		External Power Supply Input Switch
Fuse	13	Battery Negative (-) Fuse
Fuse	14	Battery Positive (+) Fuse
Fuse	15	T Phase Input Fuse
Fuse	16	S Phase Input Fuse
Fuse	17	R Phase Input Fuse

3.4.4 10kVA-120kVA UPS General View

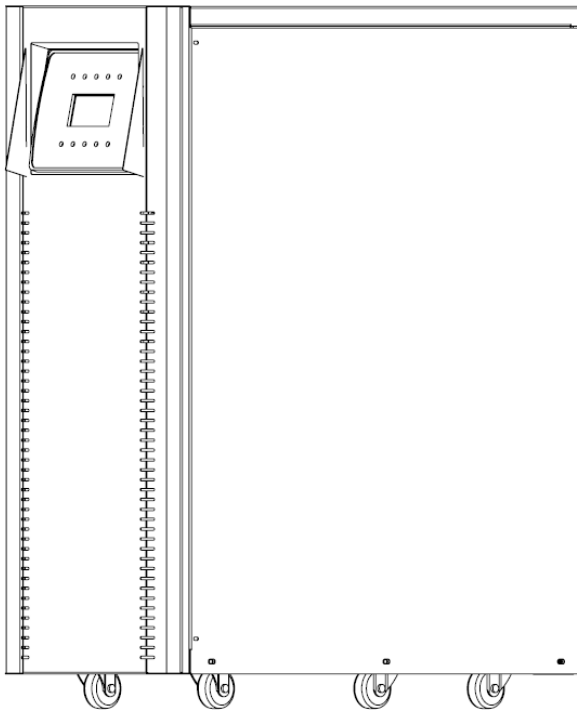

3.5. Protective Earth (PE) Connection Description



RISK OF VOLTAGE BACKFEED

- *Isolate Uninterruptable Power Supply before working on this circuit.*
- *Then check for Hazardous Voltage between all terminals including the protective earth (PE)*



Swiith the circuit breaker on UPS and distribution panel to “OFF” position before making the connections.



Swiith the circuit breaker on the distribution panel to “OFF” position before making the installation

UPS's connection terminals are on the back. In order to make the connections, the cover covering this section must be removed with a suitable equipment.

After the cover is removed, the cables prepared for ground, input, output and battery must be passed through the cable holes located under the connection points.

3.6. Protective Earth (PE) Connection



The device shall be earthed for a safe and reliable operation. Connect the PE ground connectors before connecting any other cable.

“12” Input protective earth connection terminal PE of the UPS shall be connected to ground with a low impedance connection. PE terminals of the loads shall be connected to output protective earth terminal of the UPS.



If PE cables come along with the power cables; PE cable should be min. 12 cm longer than the other cables.

3.7. Input Connection



The installation and adjustment of distribution panel should be done by authorized technical person.



Swiith the circuit breaker on the distribution panel to “OFF” position before making the connections.

Please add Three-pole (3-pole) circuit breaker (equivalent UPS input breaker) to distribution panel where UPS is to be connected. Do not connect any other load to this circuit breaker

- Do not use any circuit breaker for the Neutral line. Neutral connection should be done directly from distribution neutral bus to UPS neutral.

- Connect the phase cables to the Ups’s Input mains terminals, Connect the neutral cable to the Ups’s Input terminals

- Please do not forget to 300mA add leakage current relay to the distribution panel.

- Relay must be protected type against peak current that can be happened on EMI filter capacitor.



According to EN 62040-3, the user should place a warning label on the input distribution panel and the other primary power isolators, in order to prevent the risk of voltage feedback.

The label should carry the following indication:

RISK OF VOLTAGE BACKFEED

Isolate Uninterruptable Power Supply before working on this circuit.
Then check for Hazardous Voltage between all terminals including the protective earth (PE)

3.8. Battery Connection



Devices with internal batteries may have dangerous voltages on the battery terminals.

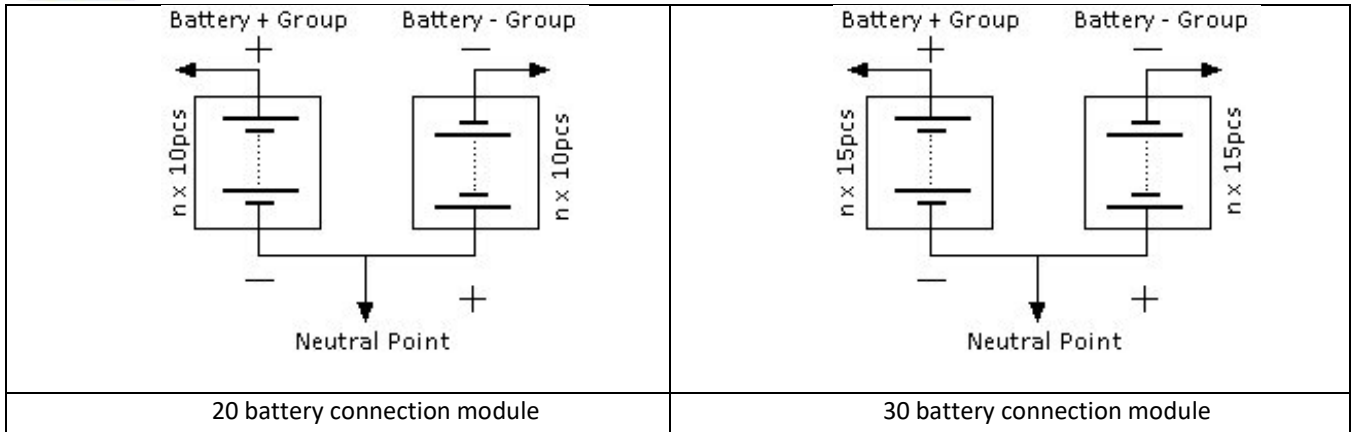

If the batteries are inside the UPS cabinet (UPS with built-in battery), no connection is required, but the battery main cables are sent as disconnected to prevent dangerous voltages from occurring in the UPS during shipment. For this reason, the covers of the UPS with internal battery should be opened and battery + (Positive) / - (Negative) and N (Neutral) cables must be installed.

If the batteries shall be put in a separate additional battery cabinet, please follow up the instructions below;

- Switch on to “OFF” position the battery cabinet circuit breaker.
- Connect the “-“on the battery cabinet to “-“on the UPS.
- Connect the “+“on the battery cabinet to “+“on the UPS.
- Connect the “BATT N“on the battery cabinet to “BATT N“on the UPS.

Connect between battery circuit breaker and battery terminals with using proper cross-section Positive , Negative and Neutral cables.(Ask manufacturer for proper cross-section)



Danger of explosion and fire if the batteries of the wrong type are used.



The batteries must be charged min. 10 hours before first-use.

3.9. Output Connection

Please add three-pole circuit breaker (equivalent to UPS output breaker) to distribution panel where the loads are to be connected. Do not use any fuse for the Neutral Line and Neutral connection should be done directly.

Connect the phase cable to Ups's output terminal and the neutral cable to Ups's output terminal.



To enable the short circuit protection feature of the UPS, each load shall be supplied through a separate circuit breaker chosen according to the load current. This may provide quick disconnection of the short circuited load and maintain operation continuity of the other loads. To obtain maximum protection, the rating of each individual load circuit breaker shall have The minimum value, which is enough to carry the full load current continuously.



Each load should be supplied through separate circuit breaker and the cable cross section should be chosen according to the load current value.



Make sure that the UPS is not overloaded to provide a higher quality supply to the loads.

3.10. Dry Contacts Connection

RS485	NC	NC	EPO	RL4	RL3	RL2	RL1
for RS485 pin 4 (+) pin 6 (-)	Not Use	Not Use	EPO	Not Use	General Fault	Input2 Mode	Input1 Mode
for RS232 pin 2 tx pin 3 rx pin 5 gnd							

3.11. Serial Communication (RS232)/External SNMP Adapter

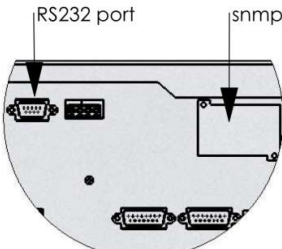
 <p>The diagram shows the rear panel of the UPS. On the left, there is an RS232 port. To its right is an snmp slot. Below these, there are two RJ45 ports. The entire panel is shown within a circular outline representing the UPS chassis.</p>	<p>UPS is equipped with Serial Communication as standard. RS232 connection (DSUB-9 male connector):</p>
---	---

It is the communication tool of the UPS with the peripheral units.

RS232 Pin LAYOUT

pin	pin	pin
2	2	2
3	3	3
5	5	5

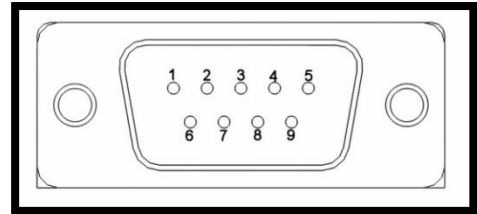

The hardware and software listed below can be used with this port;

- **Monitoring Software (Optional):** This software is installed on a computer. To establish communication between the UPS and a computer, connect your computer to the UPS communication port using the RS232 communication cable. With the software; many ups parameters such voltage, current, frequency ...etc can be monitored.
- **External SNMP Adapter (Optional):** This is a communication protocol that was designed and developed to enable monitoring and controlling of multiple UPSs from a single center simultaneously. Each UPS that will be used in network environment is connected to network over an SNMP adaptor. By IP address assignment SNMP adapter is connected to current network, hence UPS can be monitored on web browser interface. Over SNMP communication; battery test can be started or current test can be cancelled. UPS can be shut-down or stand-by (stand-by duration is adjustable). Alarms can be discarded.

Via SNMP; the information listed below can be monitored;

- The Latest Battery Test Date
- UPS Information (example: 220V - 50Hz)
- Input Data (Vin, Fin, Vmax vb.)
- Output Data (Vout, Load Percentge...etc.)
- Battery Situation (Vbatt...etc)

In order for the UPS to communicate with the above software and hardware, a serial communication cable must be used between the UPS and the software or hardware.

- **Service Software:** This software is used only by authorized Technical Service Personnel.
- Do not let unauthorized to use this software; otherwise, damage may occur to your equipment and void your warranty
- If Serial Communication cable is needed, it can be produced according to the pin configuration described as below

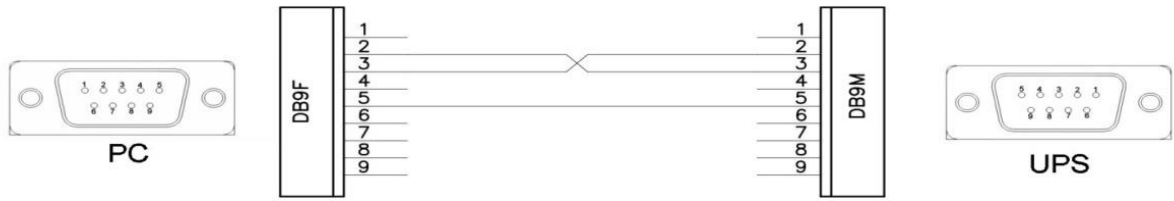

Cable Schema of Serial Communication

3.12. Emergency Power Off and External battery cabinet temperature measurement (Optional)

Ups shutdown remotely and external battery temperature sensor can be connected to the ups by using two digital inputs at communication interface .

- Voltage to be applied to the digital inputs is 5V DC.
- Maximum current drawn by each input is 1 mA..



Pay attention to the polarity of the voltages applied to the digital input terminals.

Input	Function
UPS OFF (Emergency Power Off)	If the UPS OFF input is set high by applying 5V DC voltage on the related terminals, UPS stops generating the output voltage and stops feeding the load and also “Emergency Power Off” warning is shown on the LCD display. When the voltage on the digital input is removed, the UPS starts up according to the normal procedure.
EXT BAT TEMP	Ups measures external battery cabinet heat information. If the heat changes are above the limits in that case ups transfers to Bypass mode and give warning .

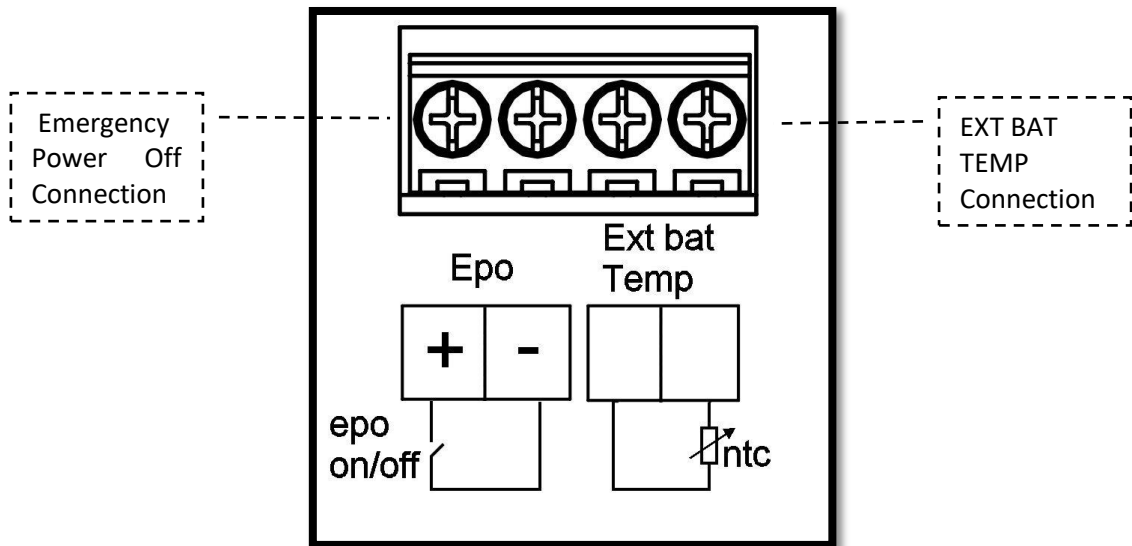

4. OPERATION MODES

This device was designed double conversion on-line system basis and three level inverter technology, it supplies all connected loads with continuous voltage with stable frequency and stable amplitude. Therefore, no transition period is necessary when electric power is interrupted or recovered.

Three-Level Inverter technology ensures high efficiency operation of the UPS. This UPS has the following operating structure.

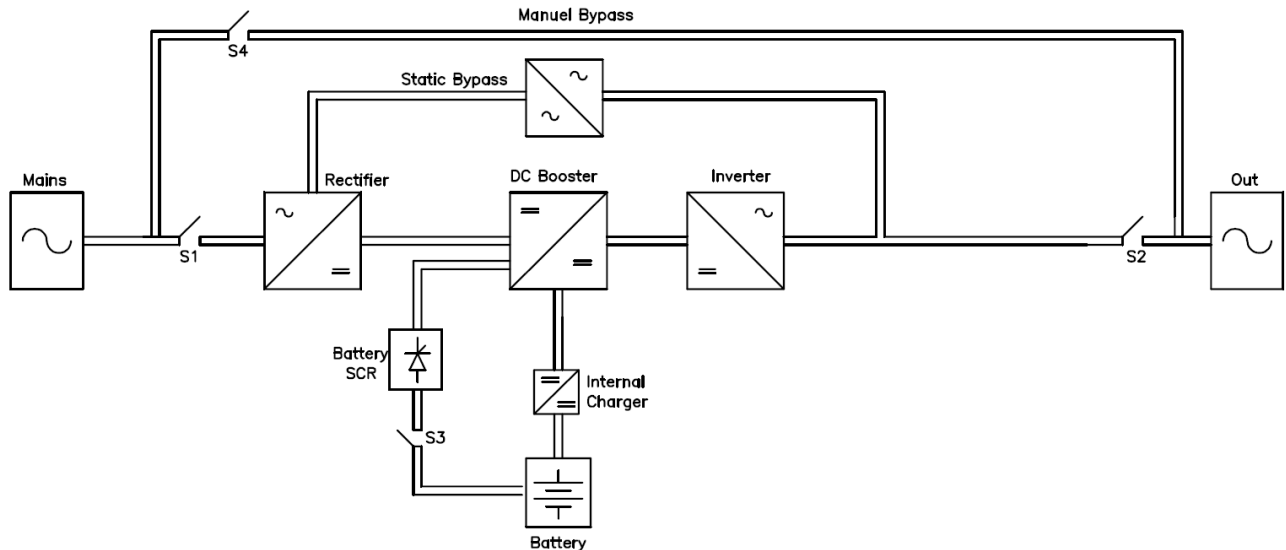

UPS BLOCK DIAGRAM

- Inverter operation provides stable pure sine wave. This pure sine wave is not affected from the input voltage fluctuations. This helps to extend the life time of your sensible loads. Power factor of the current consumed from the mains is nearly one. You do not have any problem on generator or isolation transformer applications. The reactive energy consumption decreases.

- During the mains failure, the energy needed for the load is provided by the battery in UPS (or in external battery cabinet/s). These batteries are charged by an intelligent battery charging circuit during the mains within the limits. Batteries are lead acid battery (VRLA) and do not require any maintenance until the end of their life time.

- In case of longer overload or inverter failure situation, UPS transfers the load to Bypass line, and load is supplied from the mains. When the condition turns back to normal, UPS shall continue to supply the load through inverter.

- UPS control and management is done by Digital Processor. This helps to make your UPS smarter. Processor uses all the sources on optimum conditions, observes the failure conditions, and communicates with your computer system.

- UPS can be operated in one of the following operational modes depending on the condition of mains, battery, bypass, UPS and/or user preference.

4.1 Bypass Mode

It is the operating mode in which the supply of the loads is automatically transferred from the inverter to the grid in order to protect the loads in abnormal conditions occurring in the UPS or the loads (Inverter is disabled).

In this mode, the output voltage has the same frequency and waveform as the input voltage.

In Bypass Mode, loads are fed from the mains as long as the mains voltage and frequency are within the bypass limit values.

- If the bypass input is separate, the energy is drawn from the external bypass source. As long as the external bypass voltage stays within the limits, the loads continue to be fed from this source.
- Inverter and rectifier units do not run. Load is supplied by bypass source over static bypass unit.
- Input and bypass leds turn on on the screen.

Mimic diagram is as shown in the figure;

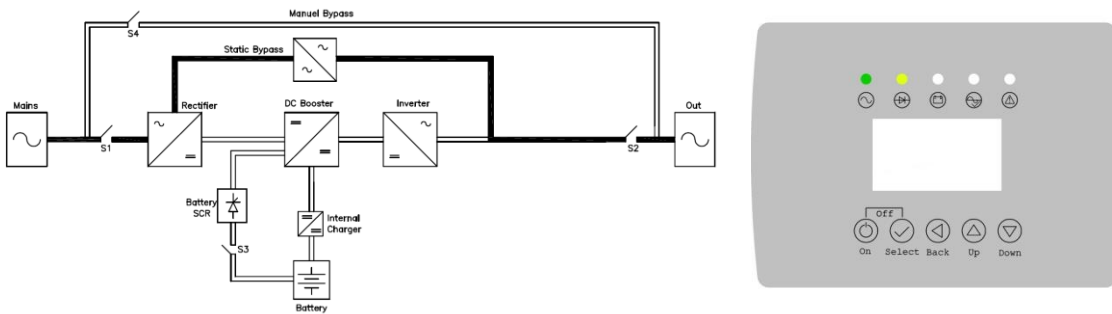

UPS operates in Bypass mode in the following cases;

- **During the start-up**
- **Inverter Fault**
- **Prolonged Overload**
- **High Heatsink Temperature**

After these conditions are eliminated, the UPS automatically returns to inverter.



Bypass Operation mode does not provide perfect stability in frequency/waveform/rms value of the output voltage like in Online Operation. Thus, the use of this mode should be carefully executed according to the level of protection required by the application.



Bypass Operation mode does not provide electronic short circuit protection as provides in Online Operation. If a short circuit occurs on the output during this operation, the thermal/magnetic protection will act and all loads will be deenergized.



In long-term overload, the thermal/magnetic protection is activated and in this condition all loads energy will be cut off.

Bypass Operation Voltage Range

The mains voltage is required to be in certain range for Bypass Operation. Voltage tolerance is set $\pm 15\%$ of the output voltage in the factory. For instance; if the output voltage is 220V, the tolerance range of bypass voltage would be 185 V – 255 V. When the mains voltage is below 175 Volts or above 255 Volts, the output is cut off.

4.2. Online Mode

. While the UPS is operating in this mode, it processes the mains voltage and supplies the loads with the output voltage set in the "Settings" menu on the front panel. In this mode, the UPS supplies the loads with the constant voltage and frequency generated by the inverter. Loads are not affected by the negativities on the network side. As shown in the figure below, the rectifier, dc amplifier, inverter, ac transmitter and charger units of the UPS are active.

- **The input and output LEDs light up on the screen.**

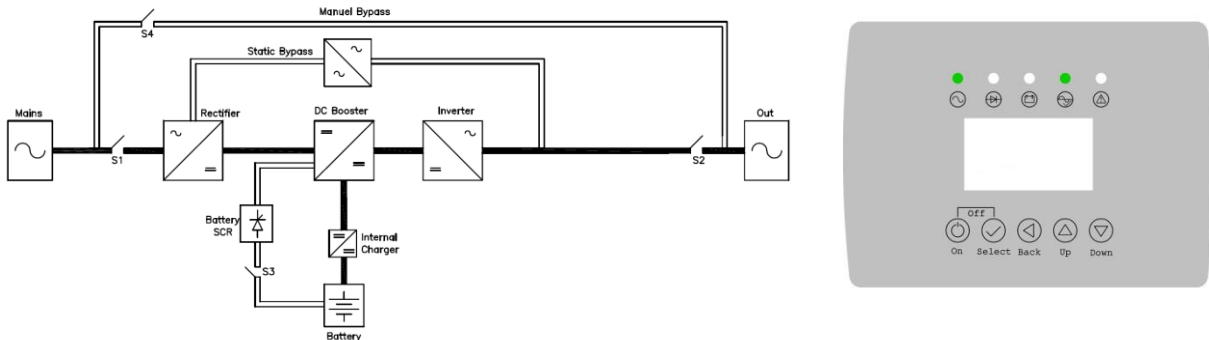

Online Mode is possible if the mains voltage is within a certain range. Mains voltage lower and upper limit values for "Online Mode" are given in the Technical Specifications section of $220V \pm 25\%$.

UPS devices supply all connected loads with continuous voltage with stable frequency and stable amplitude during online operation. Rectifier and inverter units run continuously. Load is supplied with a stable sinusoidal voltage generated by the inverter. Inverter and bypass voltages are synchronized. So, uninterruptable load transfer can be done in the UPS. Batteries are constantly kept at a buffer charge voltage.

Mimic diagram displayed on the LCD screen is as shown in figure below. During this operation mode, Input and output LED bar is constantly lit in green. If the mains voltage and frequency are in certain range, Online Operation is possible.

The upper limit of mains voltage is independent from the load percentage and it is 275V. UPS switches to Battery Operation mode when the mains is over 275V and under 165V. The mains is required to decrease below 265V and over 175V for UPS to return Online Operation. (This max/min values can make different up to required specifications)

Online Operation Conditions;

- In case Online Operation is set as operation mode of UPS, the mains is within the limits and/or if there is no abnormal condition (overheat, overload, failure...etc.) UPS operates in Online Mode. Except for failures, as soon as the abnormal conditions are eliminated, UPS switches to Online mode automatically.
- In case Bypass Operation is set as operation mode of UPS and the voltage and frequency is out of the bypass limits but within the rectifier limits, UPS switches to Online Operation.

4.3. Battery Mode

Rectifier unit does not run, inverter unit runs. Inverter unit is supplied from the battery. Load is supplied a stable sinusoidal voltage generated by the inverter. Batteries are in discharge position. In this operation, energy is drawn from the batteries. It is independent from the battery voltage. Battery voltage should be in acceptable limits and the inverter should be enabled for the UPS to operate in this mode.

- In this operation mode, Battery and Output LED bar flashes green.
- In order for the UPS to operate in Battery Mode, the battery voltage must be within the limit values.
- In battery mode; battery connector, dc amplifier, inverter and ac transmitter units are active.

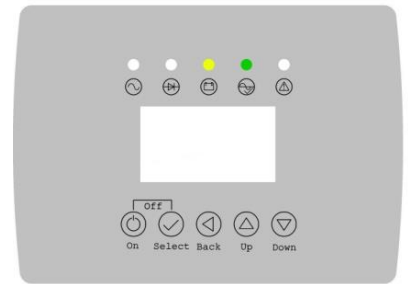
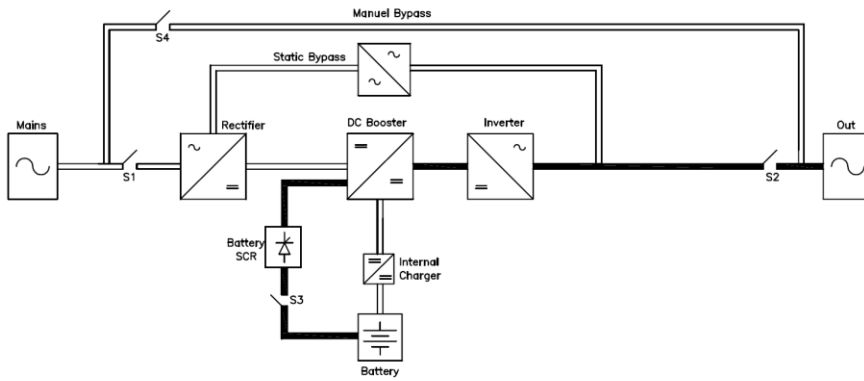

UPS operates in Battery Operation in the following cases:

- Mains voltage or mains frequency is out of limits
- Battery test procedure

4.3.1 Battery Management and Battery Back-Up Time

Autonomy time depends on battery type, quantity, capacity, situation and load level. UPS stops supplying the loads if the battery voltage decreases under a specific value.



.In order to obtain longer autonomy time, you may add batteries in an external battery cabinet. Call the technical service for this issue



Ups test batteries once in a month. If Battery Test is successful, UPS resumes normal operation. If not, "Battery test failure" alarm is displayed on LCD.

Battery life; depends on parameters such as battery type, number of charge-discharges, depth of discharge, ambient temperature. The ideal operating temperature range for the battery is specified in the Technical Specifications section. When used outside this temperature range, battery operating time and battery life will be reduced.

4.4. Maintenance –No Operation Mode

This operation mode is used for maintenance.. Maintenance and repair of the UPS can be done by authorized personnel without cut the power.

- Switch to Bypass Mode.
- Remove Manual bypass cover as shown in the figure
- Manual Bypass switch circuit breakers must be at "ON" position .
- Battery-Input-Output circuit breakers must be at "OFF" position as respectively

Call technical service.

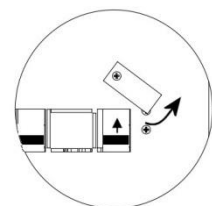



This procedure may only be executed by authorized Technical Service personnel.



Some parts inside the UPS (terminals, EMC filters and measurement circuits) are still energized during Maintenance Bypass Operation. In order to deenergize all UPS parts, circuit breakers on mains and bypass mains distribution panels feeding the UPS and circuit breakers on external battery cabinet shall be brought to "OFF" position. Internal batteries should also be isolated from the system.

Manual Bypass enables the user to isolate the electronic circuitry of the UPS from the mains and the load without interrupting the load operation by connecting the loads directly to the bypass utility supply. This feature is useful while performing maintenance or service and should only be executed by authorized technical service personnel.



During Manual Bypass operation; in case of any mains interruption occurs, all loads on the output will be deenergized. Manual Bypass Operation should not be preferred for long time use.

4.5. Closed Mode

This mode is used to make settings through Front Panel or by Service Software. To start-up Ups in Closed mode all the circuit breakers must be at "OFF" position except F2 Input circuit breaker In this mode UPS does not produce output voltage to supply the loads.









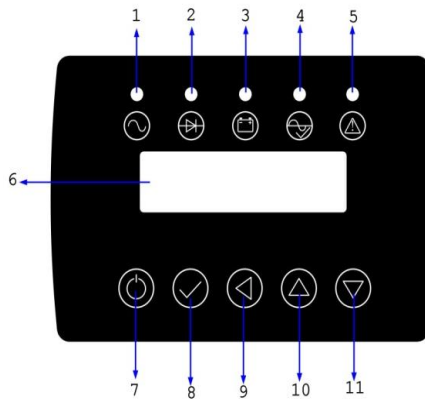

5 FRONT PANEL (LCD)

Front panel informs the user about operating status, alarm conditions and measurements. It also provides access to control and configuration parameters.

5.1 Display (LCD)

LCD screen displays UPS's current operation mode, menu, warning and failure information, system date and time, and UPS's internal temperature.



No	Indicator	Colour	Description	No	BUTTON	Description
1	 Mains Led	GREEN	It blinks green when the mains has normal conditions	7	 ON/OFF	<ul style="list-style-type: none"> ✓ Turn device on ✓ Turn device off
2	 Bypass Led	YELLOW	It blinks yellow when ups in "Bypass mode"	8	 SELECT	<ul style="list-style-type: none"> ✓ Item Selection ✓ Enter Values Accessing on the Menu
3	 Battery Led	YELLOW	It blinks yellow when ups in "Battery mode"	9	 BACK	<ul style="list-style-type: none"> ✓ Accessing on the Menu ✓ Optimizing the selected item unselected.
4	 Output Led	GREEN	It blinks green when ups in "Normal Mode" or in "Battery Mode"	10	 UP	<ul style="list-style-type: none"> ✓ Go up on the main menu ✓ Increasing the value
5	 Warning Led	RED	It blinks red when ups gives warning or when there is a failure at ups.	11	 DOWN	<ul style="list-style-type: none"> ✓ Go down on the main menu ✓ Reducing the value
6	LCD Display		LCD screen displays information about UPS			

5.2. Menu

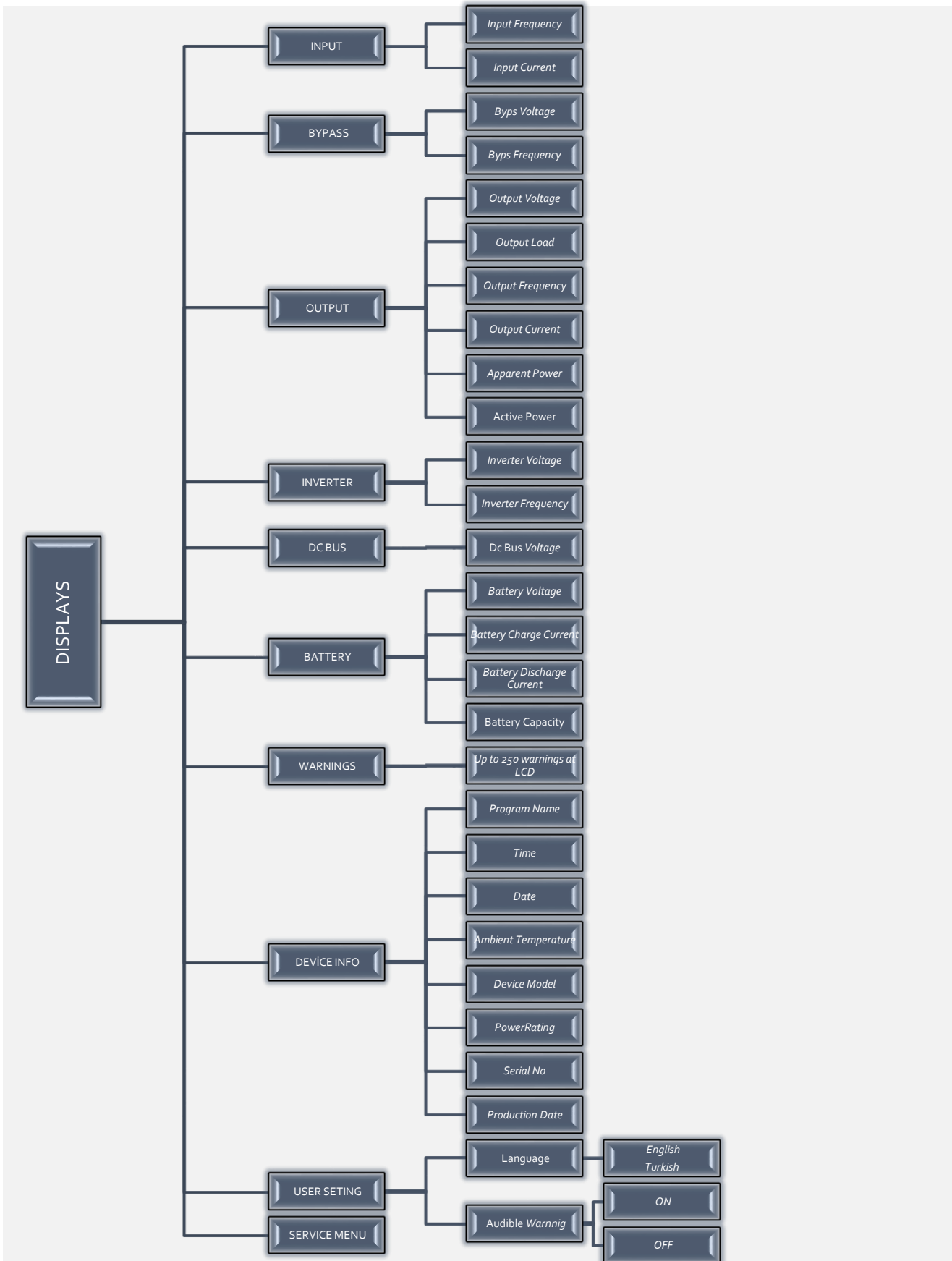

5.3. Menu and Description

The related sub-menus under the main Menu are present which provides information to user about the measurements about the UPS and status of UPS.

It can be reach to "Main menu "by pressing ENTER key. At "Main Menu" by using UP/DOWN, keys you can select requested menu . ">" sign shows selected menu at LCD. By pressing ENTER key you can enter inside of the requested menu. Use ESC key exist from menu.

Long press the ENTER button to go to the start menu from any menu.

MAINMENU	SUB MENU	PURPOSE
1 INPUT	Input Voltage	Displays mains voltage
	InputFrequency	Displays mains frequency
	Input Current	Displays input current of the ups
2 BYPASS	Bypass Voltage	Displays bypass voltage of the ups
	Bypass Frequency	Displays bypass frequency of the ups
3 OUTPUT	Output Voltage	Displays output voltage of the ups
	Output Load	Displays output load of the ups
	Output Frequency	Displays output frequency of the ups
	Output Current	Displays output current of the ups
	ApparentPower	Displays total output power of the ups
	Active Power	Displays active power of the ups
4 INVERTER	Inv Voltage	Displays input voltage of the ups
	Inv Frequency	Displays input frequency of the ups
5 DC BUS	Dc Voltage	Displays + dc bus voltage of the ups
6 BATTERY	Battery Voltage	Displays battery voltage of the ups
	Battery Charge Current	Displays battery charge current of the ups
	Battery Discharge Current	Displays battery discharge current of the ups
	Batt Capacity	Displays approximately battery capacity of the ups
7 WARNING	1-250	Displays warnings of the ups
8 DEVICE INFO	Program Name	Displays micro controller program name of the ups
	Time	Displays real time of the ups
	Date	Displays date of the ups
	Ambient Temp	Displays Ambient temperature of the ups
	Device Model	Displays device model of the ups
	Device Power	Displays device power of the ups
	Serial Number	Displays serial number of the ups
Product Date	Displays production date of the ups	
9 CUSTOMER SETTINGS	Language	Displays language of the ups
	Warning	UPS gives audible warning when there is a failure or error.It can be disable the audible sound.
10 SERVICE		Must be use only with authorized person otherwise ups will be out of warranty.

6. START-UP

6.1. Ups Start-Up

After all connections are completed, Ups must be start-up.

Switch the input circuit breaker(F2) and output circuit breaker (F3) on the ups and distribution panel to "ON" position. Press continuously 3 sec to ON/OFF key from Lcd panel. Buzzer sound and Lcd light will occur. If mains is inside of the limits from Lcd display bypass led and input led will blink and "Mains start up" letter displays at Lcd panel. Dc bus voltage and inverter voltage occurs. Switch the battery circuit breaker (F1) to "ON" position. Input and output green Led's will blink at front panel.

Afterwards UPS starts to supply the loads.

To make battery test at ups switch the input circuit breaker (F2) on the ups to "OFF" position. Ups transfers to "Battery Mode" and battery led and output led blinks at panel.

By remaking "ON" position to the input circuit breaker (F2), ups continues to work at normal mode.

6.2. Ups Shutdown

Close all Ups connected output loads safely. Switch Ups from "Normal mode" to "Bypass mode". By 3 sec continuously pressing to ON/OFF key close LCD panel. Switch the battery circuit breaker, input circuit breaker and output circuit breaker to "OFF" position.



All the maintenance operations should be done by manufacturer technical service personnel or authorized Technical Service Personnel.



Hazardous voltage and high temperature metal parts inside even if the UPS is disconnected. Contact may cause electric shock and burns. All operations except replacing battery fuses shall be carried out by the authorized Technical Personnel only.



In order to deenergize all UPS parts, circuit breakers on mains and bypass mains distribution panels feeding the UPS and circuit breakers on external battery cabinet shall be brought to "OFF/O" position. Internal batteries shall also be isolated from the system.



During Manual Bypass, the load is fed directly from the mains. Therefore, there is no protection against disturbances or interruptions in the grid.



During Manual Bypass all switches are at "OFF" position except manual bypass (F3) switch. Some parts inside the UPS (terminals, EMC filters and measurement circuits) are still energized during maintenance bypass operation.

6.3. Emergency Power Off (EPO)

UPS output can be cut off immediately by EPO connection if desired.

In case EPO connection is used in distance; a latched switch can be used as described in below figure. When UPS operates in Online Operation; if EPO is needed you have to make the switch opened or closed regarding to EPO contact mode settings you have done before to turn the UPS off.

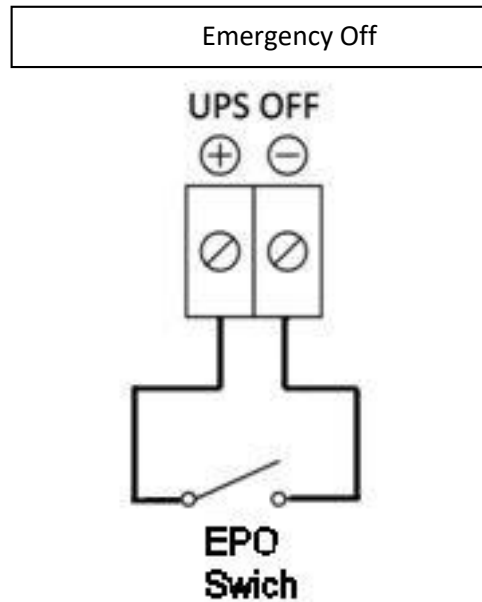

EPO switch should be placed where unauthorized people can not reach it. Unauthorized use may cause the load be deenergized.

7. MAINTENANCE



All the maintenance operations should be done by authorized Technical Service Personnel



Hazardous voltage and high temperature metal parts inside even if the UPS is disconnected. Contact may cause electric shock and burns. All operations except replacing battery fuses shall be carried out by the authorized Technical Personnel only.



In order to deenergize all UPS parts, circuit breakers on mains and bypass mains distribution panels feeding the UPS and circuit breakers on external battery cabinet shall be brought to "OFF/O" position. Internal batteries shall also be isolated from the system.

. Maintenance includes fully control of all the electronic and mechanical components in UPS. And they needed to be replaced after their lifetime is over. Systematic maintenance ensures to improve UPS's efficiency and to extend life-time. Manufacturer recommends every 6 months of period for systematic maintenance after warranty by authorized service.

7.1. Batteries

The life of batteries strongly depends on the usage and environmental conditions. (ambient temperature, frequency of electricity cuts, etc.). There are also other factors like the number of charge-discharge cycles and discharge depth.

The UPS automatically tests the batteries at regular intervals. In addition, the batteries should be checked regularly by the authorized service. Thus, undesirable results in any power outage are prevented.

Performing battery test can provide you information about battery condition.



Do not open or mutilate batteries. Released electrolyte is harmful to the skin and eyes. It may be toxic



When replacing batteries; use the same quantity and type that were originally fitted



Danger of explosion and fire if the batteries of the wrong type are used.



Batteries must always be disposed of according to local environmental laws.

7.2. Fans

Fans are used to expel the hot air inside the UPS and to cool some materials.

The life of fans used to cool the power circuits depends on the usage and environmental conditions.

Please look at Appendix Technical Specifications for detailed environment conditions.

Preventive maintenance shall be done by authorized Technical Personnel periodically.

8. TROUBLESHOOTING

The aim of this chapter is to understand some specific problems, to verify the cause of the problems and to provide solution to them.



Hazardous voltage and high temperature metal parts inside even if the UPS is disconnected. Contact may cause electric shock and burns. All operations except replacing battery fuses shall be carried out by the authorized technical personnel only.

First things to do:

1. Check and verify that PE connections are done properly.
2. Check and verify if all the cables are connected to the right terminals
3. Check and verify if the mains exists and if it is between the limits
4. Check and verify that all the circuit breakers for UPS in the distribution panel are at "I" position.
5. Check and verify that all the circuit breakers of UPS are at "I" position.
6. Check and verify that Input/Bypass sequence is correct.

8.1. Output Short Circuit Alarm

If a short circuit occurs at the output of the unit, UPS acts like a current source (as long as the over current is drawn, it decreases the output voltage keeping the output current constant at a certain value) forcing to trigger the circuit breaker that is between the UPS and the short-circuited load.

By triggering the mentioned circuit breaker, the short circuited line is being removed and the other loads that are present on the other lines are being prevented to be affected from this failure.



To enable the short circuit protection feature of the UPS, each load shall be supplied over a separate circuit breaker chosen according to the load current .Additionally UPS should operate in Online or Battery Operation.

During "Output short circuit" alarm occurs;

Switch the output circuit breaker of Ups to "0" position than switch the input circuit breaker of the ups "I" position and start-up the ups with Online operation. After display "Normal Mode" at Lcd display switch output circuit breaker of Ups to "I" position . If the rating of each individual load circuit breaker is well-adjusted; the circuit breaker of short circuit load would be blown, If not well-adjusted, "Short Circuit Alarm" would be shown on LCD. In this case the short-circuited load should be found-out and removed(In order to operate the UPS in Normal Mode, the mains voltage must be within a certain range.)

8.2. Battery test failure Alarm

UPS tests the batteries periodically. In case the batteries failed in the battery test, this alarm appears. Perform the test again when the batteries have been charged for min. 10 hours and verify the battery circuit breaker is at "I" position.

If the alarm continues, contact to authorized Technical Service

8.3. Faults Warnings

Battery Error	It is the case that the battery capacity is not sufficient when the battery test is performed on the UPS. All or some of the batteries have failed.
Input voltage high	The Input Voltage has exceeded the maximum voltage specified in the Specifications table.
Input voltage low	Input Voltage has dropped below the minimum voltage specified in the Specifications table.
Synchronous error	The frequency of the input voltage is outside the limits for input operation or the input voltage is too low.
DC voltage high	DC bus voltage is higher than its upper limit.
DC voltage low	DC bus voltage is lower than its lower limit may mean that the battery is empty during battery operation.
Ambient temperature high	Ambient temperature exceeds its upper limit. In this case, the UPS continues to operate normally, but gives an audible warning.
Over heat	Heatsink temperature exceeds its upper limit.
Output voltage failure	Output voltage is beyond its limits
Output short circuit	Short circuit at the output.
Emergency power off active	Emergency stop is activated.
Battery low	Battery voltage is lower than its lower limit. Batteries are discharging after a mains failure.
Battery high	Battery voltage is higher than its upper limit.

Note: UPS, If Input Voltage is between 47.5-52.5Hz, Synchron to Mains,

Input voltage between 45-47.4 and 52.6-55Hz gives 50Hz output to the Network Without Synchronous.

If the Input Voltage is Less than 45Hz or Higher than 55Hz, it will switch to Battery Mode.

9. APPENDIX: Technical Specifications

Cihaz Modeli	MLT 10KVA	MLT 15KVA	MLT 20KVA	MLT 30KVA	MLT 40KVA	MLT 60KVA	MLT 80KVA	MLT 120KVA
Nominal Power (kVA)	10	15	20	20	40	60	80	120
Nominal Power (kW)	10 (U1) 9 (U2) 8 (U3)	15 (U1) 13,5 (U2) 12 (U3)	20 (U1) 18 (U2) 16 (U3)	30 (U1) 27 (U2) 24 (U3)	40 (U1) 36 (U2) 32 (U3)	60 (U1) 54 (U2) 48 (U3)	80 (U1) 72 (U2) 64 (U3)	90 (U2) 80 (U3)
General								
Technology	3-Level, Double conversion Online VFI-SS-111							
Waveform	Sinusoidal							
Architecture	Stand Alone or Optional Paralel							
Input								
Input Voltage	220, 230, 240 V 1PH+N+PE							
Input Frequency	45-65 Hz							
Voltage Tolerance (%100 load)	(-20)% (+20)%							
Voltage Tolerance (%50 load))	(-40)% (+20)%							
Input Power Factor	>0,99							
Input Current Harmonic	≤5%							
Output								
Output Voltage	220,230,240 V 1 Ph+ N+PE (Adjustable from front panel)							
Output Voltage Tolerance	0,01							
Overall Efficiency (AC-AC)	Up to 95,5 % (At half load)							
Ecomode Efficiency	Up to 98,5%							
Nominal Output Frequency	50/60Hz +0,01 free run (Adjustable from LCD Panel)							
Crest Factor	3 : 1							
Output Power Factor	(U1 Model) PF:1 / U2 Model) PF:0,9 / (U3 Model) PF:0,8							
THD of Output Voltage	<%2 (at full linear load)							
Bypass								
Overload Capability	150% for 1 minutes							
Bypass	Built in Automatic and Maintenance Bypass							
Voltage Tolerance	±10%							
Battery								
Battery Type	VRLA-AGM Maintenance-Free							
Battery Test	Automatic and Manual							
Battery Recharge Time	<6h-8h							
Battery Quantity	U3 20 Adet 9Ah U1 / U2 32 Adet 9Ah	32 Adet 9Ah	U2/U3 32 Adet 9Ah U1 60 Adet 9Ah	60 Adet 9Ah 40adet 12Ah	U2/U3 60 Adet 9Ah U1 60 Adet 18Ah U1 108 adet 9Ah U1 72 adet 12Ah U1 60 adet 18Ah	108 adet 9Ah 72 adet 12Ah 60 adet 18Ah	Dahili Akü Montajı Yapılmıyor	
External (With Adjustable Digital 13A Charger)	28-46 adet							
Charge Current								
Standard Charger Card	4A					13A		
Digital Charger Card	13A (U1 Model)					13A		
Communication								
LCD Display	Graphical lcd screen, Led bar status							
Communication ports (Optionals)	RS232, Genset, SNMP, Relay Contacts, Input Contacts, Modbus and USB (optional)							
Accessories (Optional)	Available							
Physical Characteristics								
Dimensions H x W x D (mm)	257x680x760		257x680x760 (U1) 325x895x1078	325x895x1078	325x895x1078 (U1) 420x940x1330	420x940x1330 (U1) 432x930x1257	432x930x1257	
Net Weight (kg)	45 / 48 (U1)	48	48 / 69 (U1)	69	69 / 97 (U1)	97 / 103 (U1)	103	125
Ambient Conditions								
Operating temperature (°C)	0°C - 40°C							
StorageTemperature	-15°C+ 55°C							
Relative Humidity (%)	< 95% not condensing							
Noise at 1 m (dBA)	<55							
Protection Class	IP 20							
Compliance								
Reference Product Standards	EN 62040-1-1 (Safety), EN 62040-2 (EMC), EN 62040-3 (Performance)							

10. WARRANTY

10.1. Terms of Warranty

- Warranty period of UPS; Provided that it is used as shown in the user manual and has not been intervened for maintenance, repair and/or any other reason by persons other than the service personnel authorized by the Manufacturer, all parts of the UPS, including all material, workmanship and production faults, are 2 years from the delivery of the product. .
- In case the goods fail within the warranty period, the time spent in repair is added to the warranty period. The repair time of the goods is a maximum of 20 working days. This period starts from the date of notification of the product defect to the service station, or in the absence of a service station, to one of the product's seller, dealer, agency, representative, importer or manufacturer. If the defect of the industrial goods is not fixed within 20 working days, the manufacturer or the importer; Until the repair of the good is completed, it has to allocate another industrial good with similar characteristics to the use of the consumer.
- In the event that the product fails during the warranty period, due to material and workmanship or assembly errors, it will be repaired without any charge under any other name, such as labor cost, replacement part cost or any other name.
- Despite using the right to repair, the consumer may request free replacement of the goods, refund or discount at the rate of defects due to the following situations;
 - ❖ The fact that the same malfunction is repeated more than twice within a year from the delivery date, or that different malfunctions occur more than four times, or that the sum of different malfunctions is more than six within the specified guarantee period, as well as the continuity of not being able to benefit from the product as a result of these malfunctions,
 - ❖ Exceeding the maximum time required for repair,
 - ❖ In case the service station is not available, it is determined that it is not possible to repair the fault with a report to be issued by one of its dealers, dealers, agents, representatives, importers or manufacturers, respectively,
- Defects resulting from the use of the product contrary to the terms in the user manual are not covered by the warranty.
- For problems that may arise regarding the warranty certificate, the General Directorate of Protection of Consumers and Competition under the Ministry of Science, Industry and Technology can be applied.

10.2. Out of Warranty Terms and Conditions

This warranty given by the manufacturer does not cover the faults that may arise from the abnormal use of the UPS, and it is also out of warranty in the following cases:

- If the UPS is not used or installed according to the terms in the manual, then the UPS is out of warranty,
- Damages and malfunctions that occur during loading, unloading and transportation after the UPS is delivered to the customer,
- Faulty electrical wiring; Damages and malfunctions caused by using a voltage different from the voltage written on the label of the product,
- Malfunctions and damages that may occur due to natural disasters such as fire and lightning strikes and floods.
- Damages and malfunctions caused by usage errors,
- If the product is intervened with by unauthorized persons, the warranty given to the product will expire.

Repairing of the above-mentioned faults is done for a fee. Installation and shipping of the product are not included in the product price.

The responsibility of giving the guarantee certificate to the consumer after it has been perfected belongs to the seller, dealer or representative office from which the consumer purchased the goods.

This warranty is void if the warranty document has been tampered with, the original Serial Number on the product and electronic cards has been removed or tampered with.